

FOR SUBDUED INSIGNIA

OCP:
 BLUE AREAS TO BE BAGBY GREEN 67204.
 YELLOW AREAS TO BE BLACK 67138.

REVISIONS

SUPERSEDES TIOH DWG. No. A-1-1125 DTD. 30 JANUARY 2018

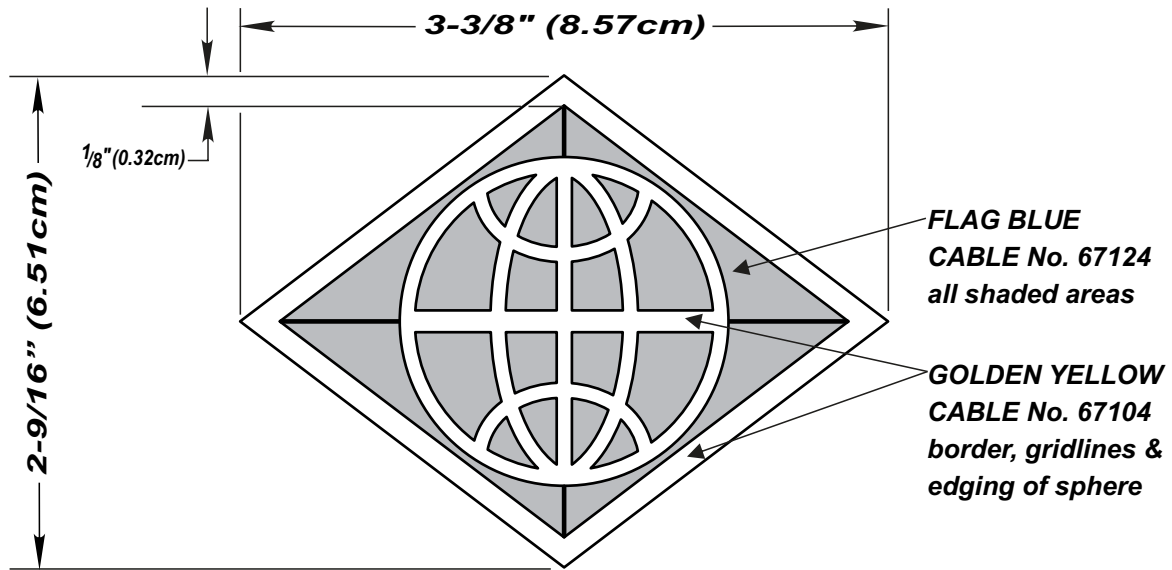

DESIGNED FOR OVEREDGE STITCHING

STITCH COUNT
STITCHES 5859 (MINIMUM)
DENIER 90/2
SPAN 12/4

EXAMINED	TLC	
CHECKED	CA	SAD
PREPARED	CAIford	
APPROVED	 CHARLES V. MUGNO DIRECTOR	
MATERIALS: TO BE MANUFACTURED IN ACCORDANCE WITH MIL-DTL-14652		

THE INSTITUTE OF HERALDRY, DEPARTMENT OF THE ARMY		
9325 GUNSTON RD, RM S-113 FORT BELVOIR, VA 22060-5579		
SHOULDER SLEEVE INSIGNIA		
U. S. ARMY FINANCIAL MANAGEMENT COMMAND		
SIZE	CONTROL IDENT. NO	A - 1 - 1125
A	22571	
SCALE	FULL	DATE
		10 OCTOBER 2018